

MODEL 163 as of 1.12.99

F1 Fuse and relay module

N10 All-activity module (AAM)

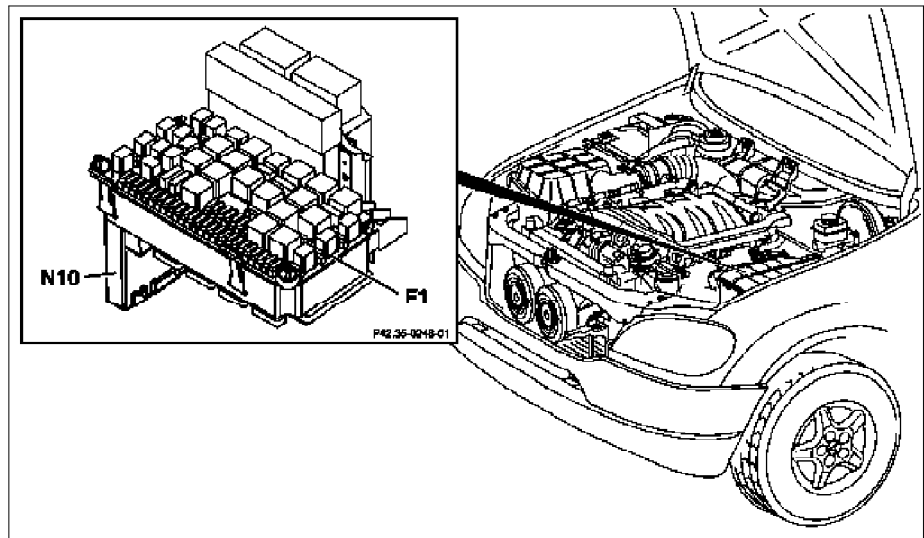

P83.30-2050-05

	All-activity module, location	The all-activity module (AAM) (N10) is plugged into the fuse and relay module (F1) from below.	
	All-activity module, task		GF54.21-P-4100-02GK
	All-activity module, design	The AAM is accommodated in a sturdy plastic housing. It is connected to the wiring harnesses by 4 plug connectors and one coaxial connection. A 50-pin strip socket connects it with the fuse and relay module (F1).	
	All-activity module, function		GF54.21-P-4110-01GK