

AR88.30-P-0200-03GH	Prepare detachable body components		
---------------------	------------------------------------	--	--

Commercially available tools (see Workshop Equipment Manual)

Number	Designation	Make (e. g.)	Order number
WH58.30-Z-1015-20A	Betapower II (2-component electric cartridge gun)	DOW Automotive (Deutschland) GmbH Am Güterbahnhof D-35683 Dillenburg Tel.: +49 (0) 39484/8714-0	995.182

Repair products

Number	Designation	Order number
BR00.45-Z-1055-02A	2K glue kit	168 670 00 93

1 Coat areas (9) on which glue is to be applied with Beta Primer 5404 from repair kit.

i Allow Beta Primer 5404 to air-dry min. 10 min., however, not longer than 15 min.

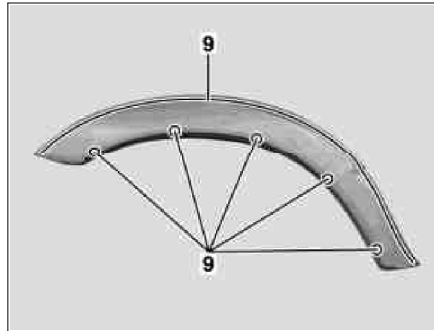

P88.30-2092-01

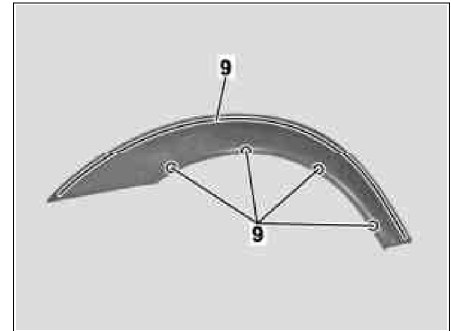

P88.30-2082-01

2 Apply glue (9) to inside of new detachable body components.

i Position tip of application nozzle on detachable body component. Immediately remove excess glue.

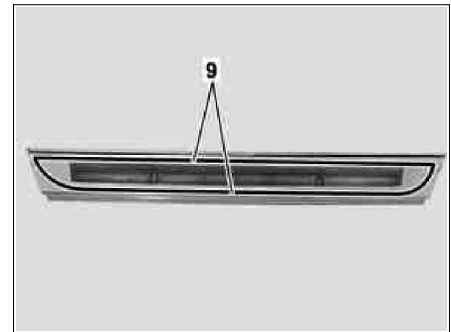

P88.30-2083-01

i Detachable parts must be glued on within 8 minutes after applying glue.

i Cut application nozzle open to create an approx. 6 mm large opening. Before applying glue, apply approx. 30 mm long bead of glue to the detachable component to ensure that the two components are mixed well.

Top edge fender components :Glue bead should be approx. 8 mm high, make contact with both sides of the gluing groove and end 10 mm before the end of the detachable body component.

Bottom edge fender components: Uniformly apply glue on spacers 30 mm wide and 20 mm high.

Component on tailgate: Glue bead should be approx. 8 mm high and should run approx. 25 mm within the edges of the detachable body component.