

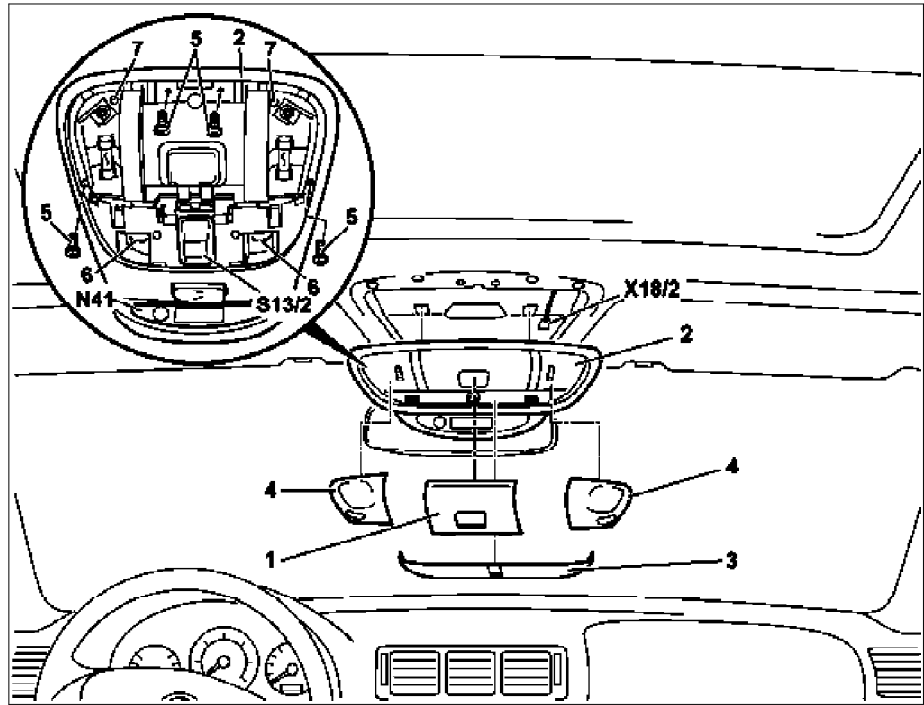







MODEL 163.113 /128 /136 /154 /157 /172 /174 /175

- 1 Garage door opener flap
- 2 Overhead control panel
- 3 Cover
- 4 Glass covers
- 5 Bolts
- 6 Retaining clip
- 7 Clips (black)
- N41 Trip computer control module
- S13/2 SR switch
- X18/2 Interior/roof connector



P68.00-0650-06

 	Remove/install		
1	Remove garage door opener flap (1) from overhead control panel (2)		
2	Unclip cover (3) on the sliding/tilting roof switch (S13/2)	 4 clips.	
3	Unclip glass covers (4) from interior lights		
4	Unscrew screws (5) below garage door opener flap (1) and glass covers (4)		
5	Unclip clips (black) (7) next to the light switches	 Installation: Counterhold mounting plate with puller hooks inside of headliner.  Hooked extraction tool	*140589023300
6	Press both retaining clips (6) to rear and simultaneously press overhead control panel (2) to front	 Position narrow plastic wedge or screwdriver in front of retaining lugs.	
7	Remove overhead control panel (2) downward		
8	Remove sliding/tilting roof switch (S13/2)		AR77.20-P-0001GH
9.1	Remove trip computer control module (TRIP) (N41)	 With code 245, trip computer, only.	AR54.50-P-0001GH
10	Detach interior/roof connector (X18/2) from overhead control panel (2)		
11	Remove overhead control panel (2)		
12	Install in the reverse order		

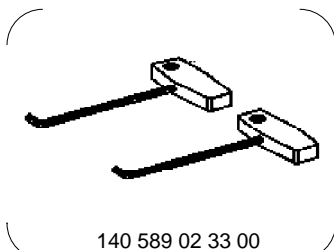

140 589 02 33 00

Hooked extraction tool