

MODEL 163.113 /128 /136 /154 /157 /172 /174 /175

- 1 Windshield wiper arms
- 2 Rubber seal
- 3 Cover
- 4 Nuts
- 5 Metal clips
- 6 Water deflector panel

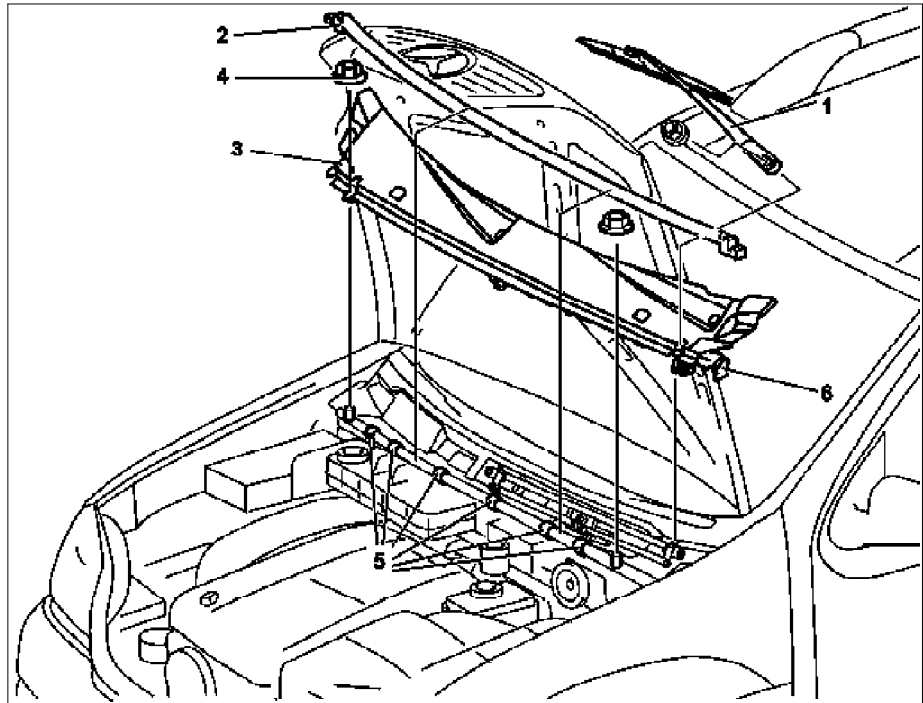

P83.25-2012-06

☒ ☒	Remove/install		
⚠ Danger!	Injury hazard by trapping or crushing, in extreme cases with loss of limbs when reaching into windshield wiper mechanism	Always remove ignition key when working on windshield wiper mechanism.	AS82.30-Z-0001-01A
1	Remove wiper arms (1)		AR82.30-P-6100GH
2	Detach rubber seal (2) from firewall		
3	Remove metal clips (5)		
4	Unscrew nuts (4) at firewall	ⓘ Remove foam insert.	
5	Seal off washer fluid hose at check valve		
6	Remove cover (3) together with water deflector panel (6)	ⓘ If damaged, detach water deflector panel (6) from cover (3). ⓘ Installation: Lubricate upper edge of cover and windshield at bottom with soapy water.	
7	Install in the reverse order		