

MODEL 163.113 /128 /136 /154 /157 /172 /174 /175

Steering wheel removed for clarity

- 3 Upper steering column cover
12 Side covering

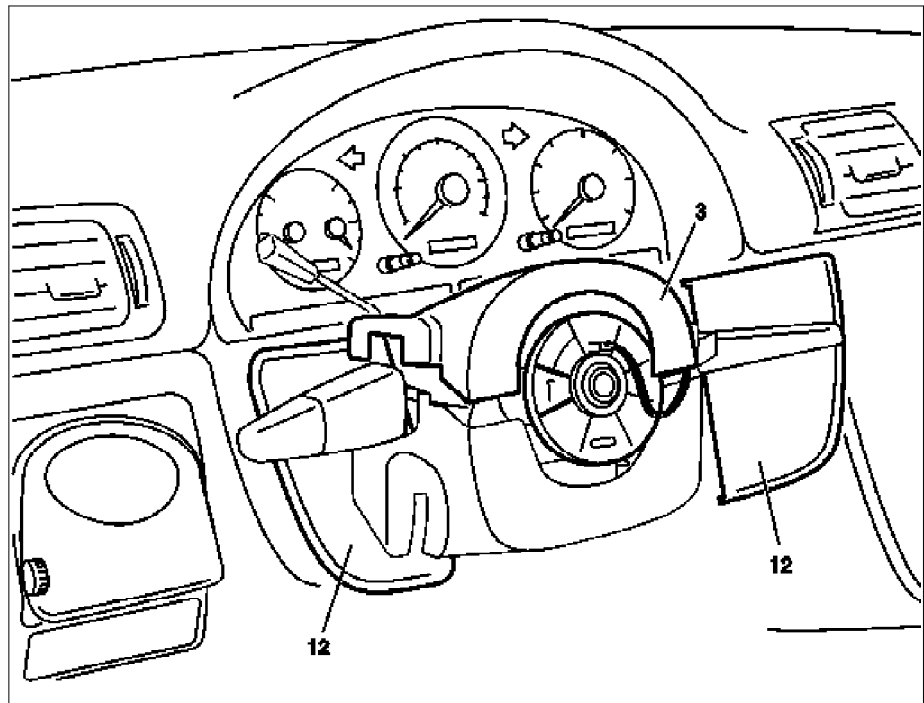

P54.25-2680-06

Steering wheel removed for clarity

- 4 Clips
5 Frames
6 Hook
7 Lug
8 Mount
9 Screw
10 Spreading clips
11 Connector
13 Mount
A1 Instrument cluster

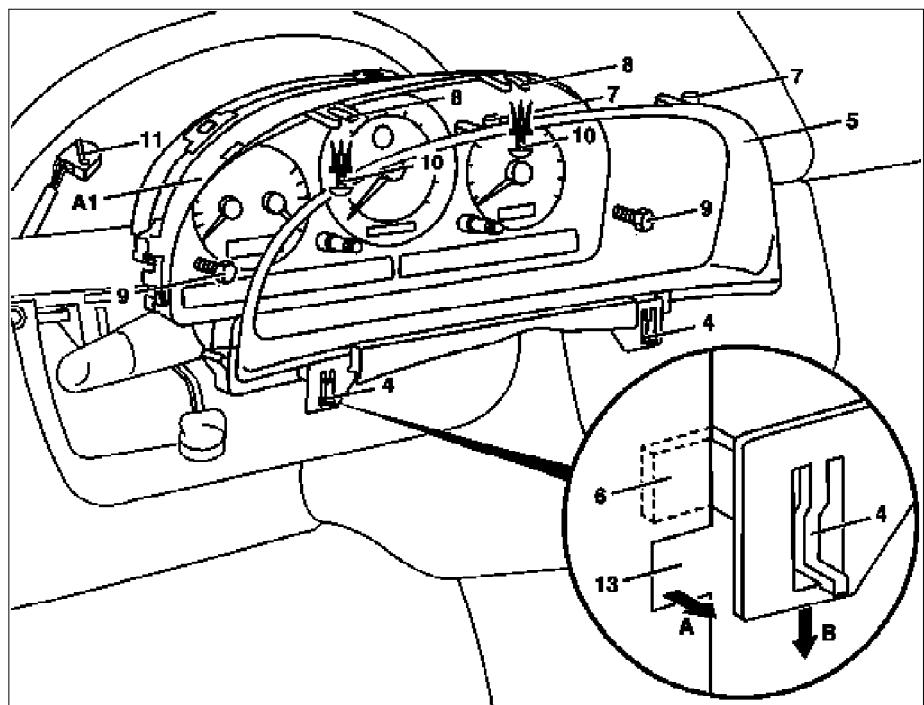

P54.30-0630-06

☒ ☒	Remove, Install		
1	Disconnect ground cable of battery	⚠ To prevent unintended contact, insulate the ground lead cable lug.	AR54.10-P-0003A
2	Unlock steering wheel and move to its lowest position	ℹ See Operating Instructions	
3	Remove upper steering column cover (3)	⚠ Risk of fracturing! Do not scratch the steering wheel. ℹ Only as of VIN A145273, X708319: Loosen clips on the side and front. Gently squeeze the cover together and pull out between the steering wheel and instrument panel.	

4	Remove side covers (12)	<p>⚠ Danger of breaking retaining lugs. Do not damage instrument panel.</p> <p>i Up to VIN A145272, X708318: 3 covers: Remove side covers first. Detach center cover from instrument panel and rotate so that the retaining lugs point upwards. Then pull out to the right.</p> <p>As of VIN A145273, X708319: 2 covers: First remove the right cover, then the left. It is not necessary to detach the connectors. The covers can remain attached to the wiring harness.</p> <p> Long wedge</p>	*115589035900
5	Remove frame (5) of instrument cluster	<p>⚠ Lift clips carefully, risk of fracture.</p> <p>i Push the clips (4) outwards (arrow direction A) and ease the frame down towards the footwell (arrow direction B) until the top of the frame disengages.</p> <p>i Installation: Insert the hooks (6) of the frame into the bracket (13) and push the frame upwards until the clips snap into place.</p> <p>i Installation: Insert the lugs (7) on the frame into the receptacles (8) on the instrument cluster.</p>	
6	Unscrew screws (9)		
7	Remove expanding clips (10)		
8	Pull instrument cluster (A1) forwards		
9	Unlock, open and pull off connector (11)		
10	Remove instrument cluster	<p>⚠ Make sure the steering wheel is not scratched.</p> <p>i Tilt the upper edge of the instrument cluster towards the steering wheel and move to the right out of the instrument panel.</p>	
11	Install in the reverse order		
12	Perform function check		
a	Instrument cluster (IC) diagnosis operational check		AD54.30-P-3000A

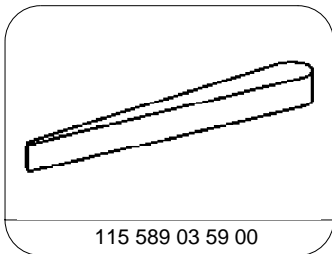

115 589 03 59 00

Assembly wedge