

MODEL 163.113 /128 /136 /154 /157 /172 /174 /175

- 1 Bolt
- 2 Lower steering column cover
- 3 Upper steering column cover
- 12 Cover

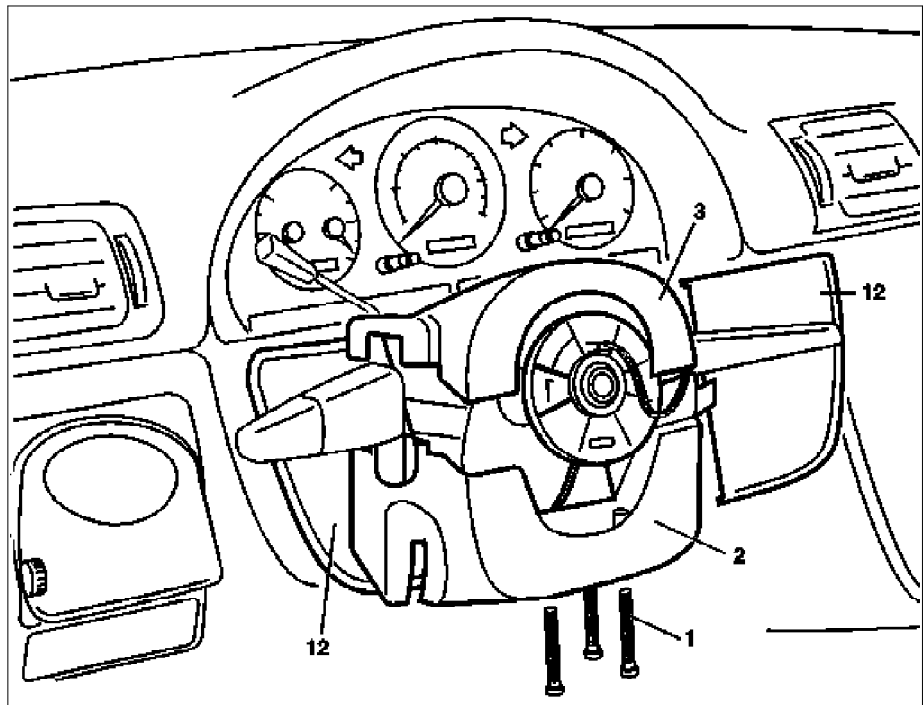



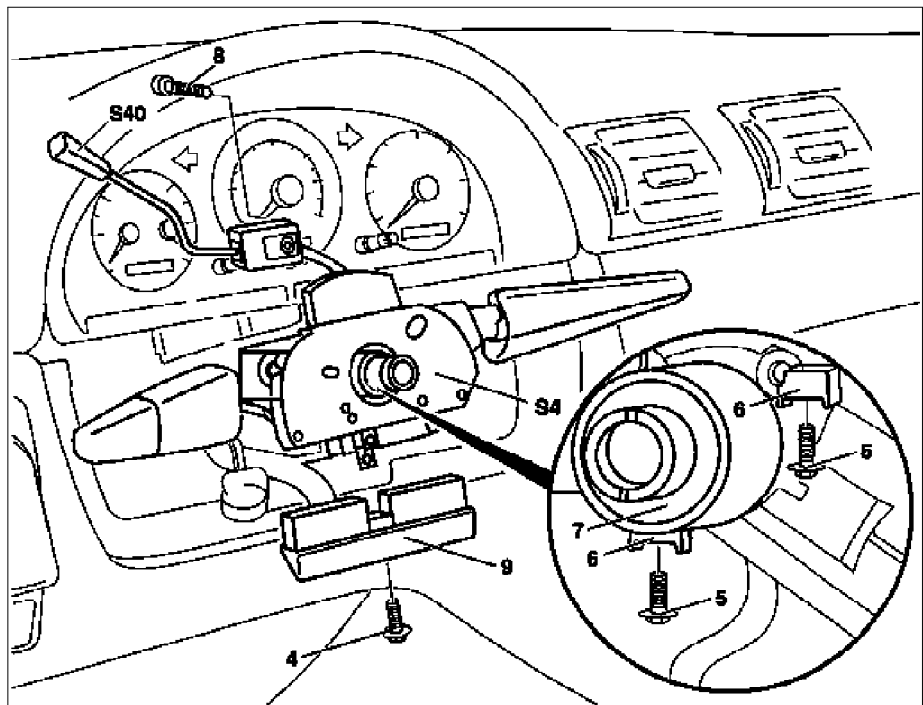

P54.25-0325-06

- 4 Bolt
- 5 Bolt
- 6 Retaining web
- 7 Steering shaft
- 8 Bolt
- 9 Connector
- S4 Combination switch
- S40 CC switch



P54.25-0333-06

 	Remove/install		
1	Disconnect ground cable of battery	 To protect against unwanted contact between the disconnected ground line and the ground (right major assemblies compartment, common ground W16/4, insulate cable lug of ground line.	AR54.10-P-0003A
2	Remove steering wheel	 Caution when handling airbag unit! Improper handling can lead to damage to the airbag unit.	AR46.10-P-0100GH
3	Remove clock spring contact		AR46.10-P-0200GH
4	Unscrew screws (1) and remove lower steering column molding (2)		
5	Remove upper steering column molding (3)		
6	Remove covers (12) on left and right		

7.1	Disconnect electrical connectors at the covers (12)	i Only with left/right folding outside mirror, code 500 and headlamp cleaning system, code 600.	
8	Unscrew screw (4) and disconnect connector (9)		
9	Unscrew screw (8) and remove cruise control switch (S40)		
10	Unscrew screws (5)		
11	Pull combination switch (S4) off the retaining webs (6) and remove		
12	Install in the reverse order		
13	Perform function check		