

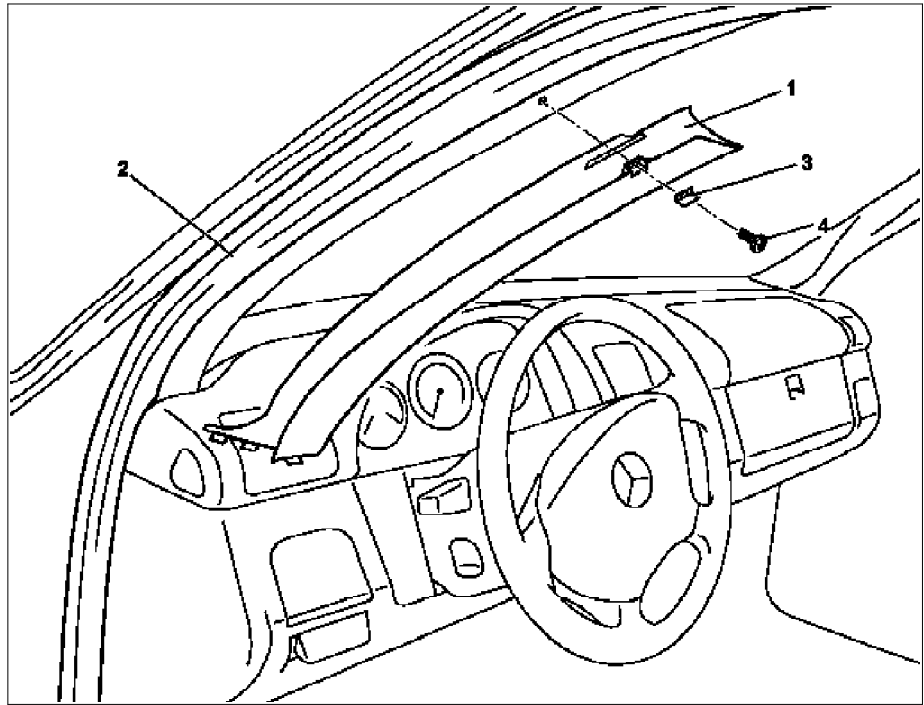



MODELS 163.113 /128 /136 /154 /157 /172 /174 /175

Vehicle illustrated up to 31.8.98

- 1 A-pillar paneling
- 2 Door rubber seal
- 3 Cover cap
- 4 Bolt



P68.30-0537-06

 	Remove/install		
1	Remove door rubber seal (2) in area of A-pillar		
2.1	Remove cap (3)	Up to 08/98.	
3.1	Unscrew screw (4)	Up to 08/98.	
4	Remove A-pillar paneling (1)	<p><b>i</b> The paneling is fastened in the instrument panel at the bottom with lugs and will be fastened with a clip at top as of 09/98.</p> <p><b>Installation:</b> Replace clip</p> <p> Long wedge</p>	*115589035900
5	Install in the reverse order	<p><b>i</b> On vehicles up to 08/98, on which a new paneling should be installed, the upper area of the fixing opening at the top of the A-pillar must be enlarged so that the clip retainer of the paneling can be installed in the A-pillar.</p>	

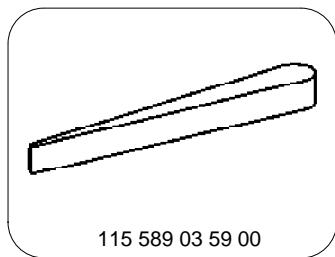

115 589 03 59 00

Long wedge