

TRANSMISSION 722.6 in MODEL 163, 170, 202, 208, 210

TRANSMISSION 722.610 in MODELS 463.209 /232 /233

TRANSMISSION 722.611 in MODELS 463.308 /330 /331

TRANSMISSION 722.630 in MODELS 463.206 /240 /241

- 33 Selector lever
 63 Shift rod
 97 Intermediate lever
 98 Rod head
 99 Bolt
 107 Floor-mounted shift

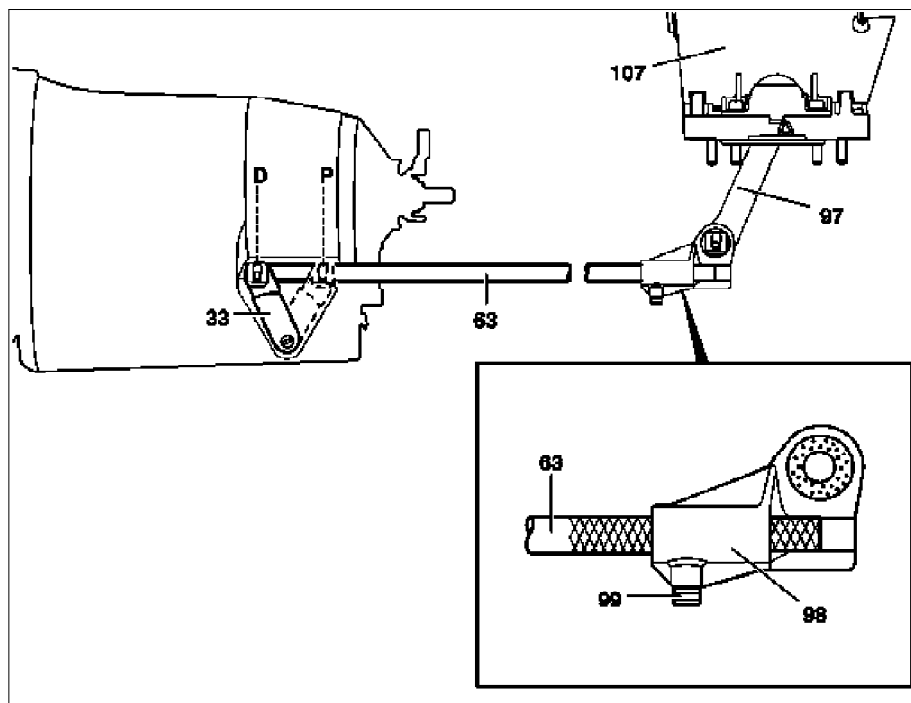

P27.60-0218-06

Operation no. of operation texts or standard texts and flat rates

Range	Op. no.	Operation text
P	271280	CHECKING SELECTOR LEVER ROD AND STARTER LOCKOUT SWITCH, ADJUSTING IF NECESSARY

Adjusting			
i	Vehicle must be horizontal and standing on its wheels	Position vehicle on the four column lifting platform.	
1	Move selector lever to position "D".	i Have an assistant hold the selector lever in position "D" for the entire duration of the adjustment work.	
2	Mount rod head (98) at intermediate lever (97) and secure with clips		*210589003700
3	Insert shift rod (63) in head and attach to selector lever (33) and secure with clips		*210589003700
4	Tighten bolt (99)	i Press against the rod head (98) to tighten. Do not twist shift rod (63) or rod head (98) Do not move selector lever (33) out of position "D". Nm	*BA27.60-P-1001-04A
5	Check function		

Nm Tightening torques for shift rod

Number	Designation	Transmission 722.6
BA27.60-P-1001-04A	Bolt in rod head M8x 10	NM 12

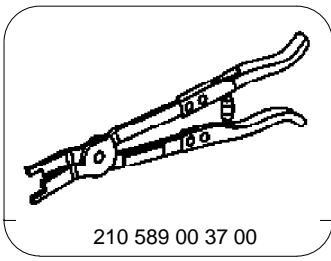

Pliers