

E1

AR42.10-P-0010GJ

Bleeding brake system

22.12.97

MODEL 460, 461, 463

1, 2 Rear brake cylinder/brake caliper

3, 4 Front brake caliper

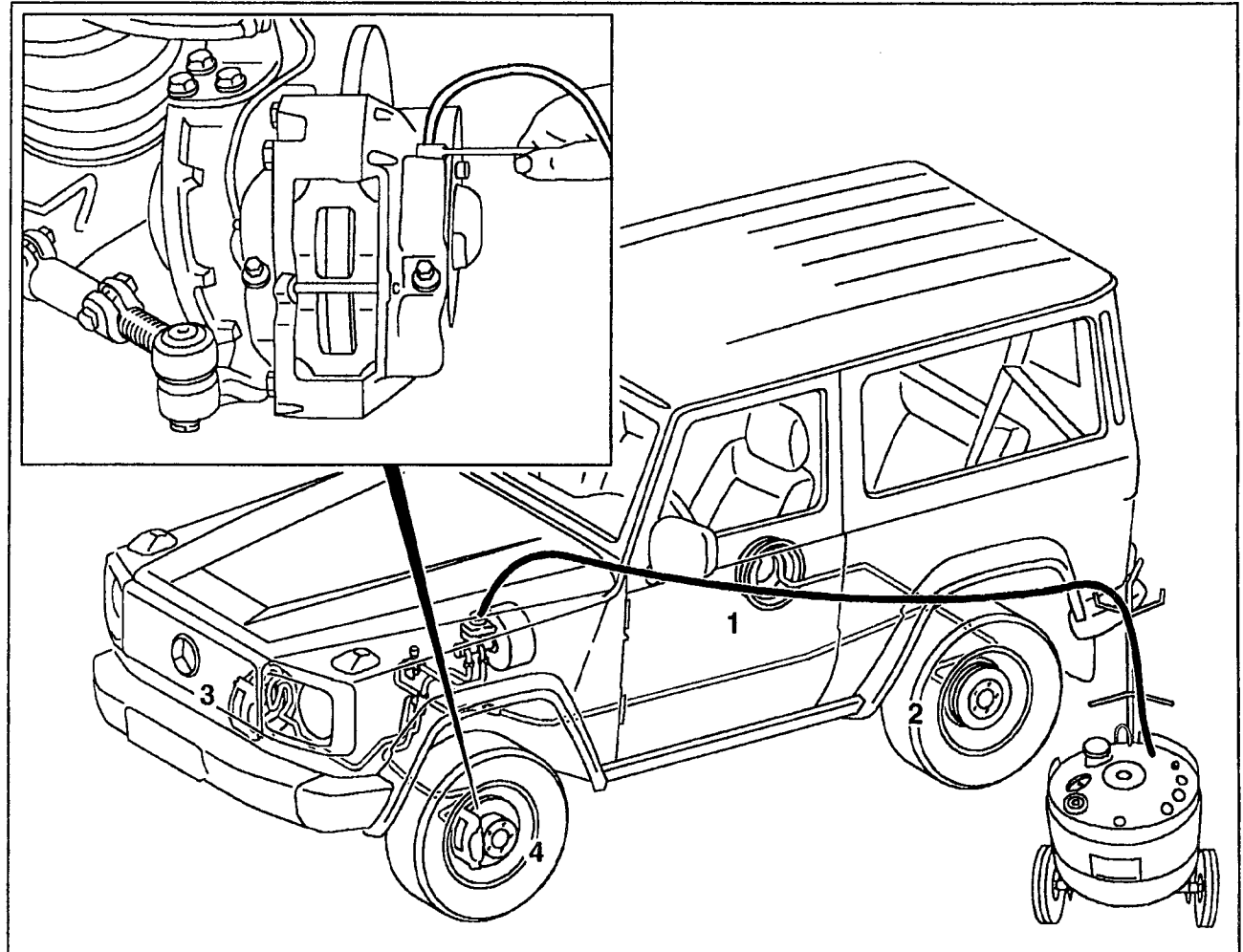

P42.10-0324-06



Illustration/item, etc.			
Danger!	Risk of poisoning due to consuming brake fluid. Risk of injury due to brake fluid coming into contact with the skin or eyes.	Only pour brake fluid into suitable, appropriately marked containers. Wear protective clothing and safety glasses when handling brake fluid.	AS42.50-Z-0001-01A K17
	Notes on brake fluid		AH42.50-P-0001-01A O17
	Notes on repairs to brake system		AH42.00-P-0003-01A P17
1	Brake fluid changing unit	Observe manufacturer's operating instructions. Bleeding pressure 2 bar Brake fluid	WE58.40-Z-1001-07A BF42.10-P-1001-01B
2	Carry out bleeding process		AR42.10-P-0010-02GG A16
3	Disconnect filling and bleeding unit, check brake fluid level and correct if necessary		

Nm Front axle fixed caliper

Number	Designation	Models 460, 461	Model 463
BA42.10-P-1001-02B	Bleed screw on front axle fixed caliper	Nm 14	14

**Nm** Rear axle floating caliper

Number	Designation		Models 461.326/335/ 336/365/366	Models 463.206/209/ 232/233/240/ 241/308/330/331
BA42.10-P-1001-17B	Bleed screw on rear axle floating caliper	Nm	12	12

Nm Brake cylinder

Number	Designation		Models 460, 461	Model 463
BA42.10-P-1001-08A	Bleed screw on rear axle wheel brake cylinder	Nm	14	14

 Brake fluid

Number	Designation		Models 460, 461	Model 463	
BF42.10-P-1001-01B	Brake fluid	Filling quantities	Liters	≈ 0.45-0.6	≈ 0.45-0.6
		Specification for Service Products	Sheet	330.1	330.1
			Sheet	331.0	331.0

Workshop equipment/MB testers (refer to Workshop equipment manual)

WE58.40-Z-1001-07A	Brake fluid changing unit
--------------------	---------------------------