

MODEL 163.113 /128 /136 /154 /157 /172 /174 /175 with CODE (580) Air conditioning or Tempmatic for USA

Shown on model 163 up to VIN A289564, X754619

- 1 A/C housing
- 3 Bolts
- 4 Connector
- M39 Recirculated air flap actuator motor

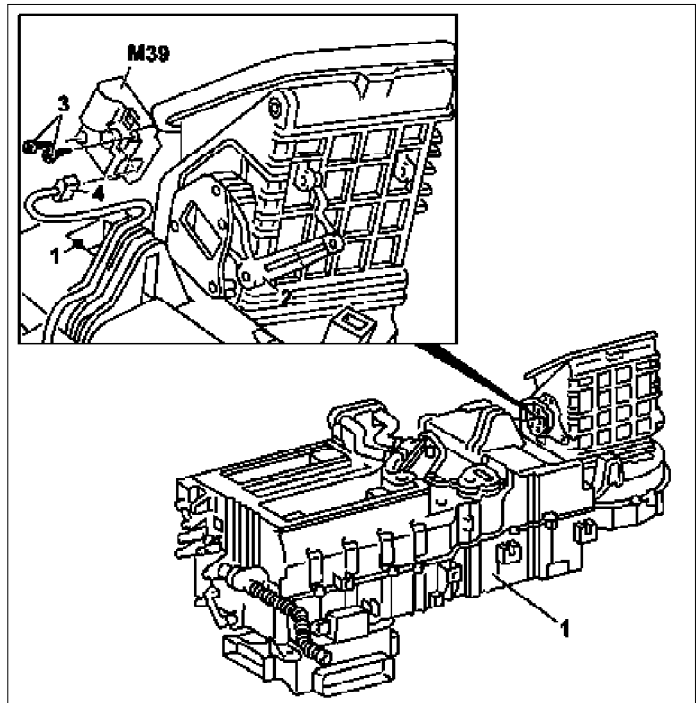

P83.30-0768-12

	Remove/install		
1	Remove instrument panel		AR68.10-P-1000GH
2	Remove front passenger airbag unit		AR91.60-P-0680GH
3	Disconnect connector (4) from recirculated air flap actuator motor (M39)		
4	Unscrew screws (3) from recirculated air flap actuator motor (M39)	3 screws are fitted as of VIN A289565 X754620.	
5	Detach recirculated air flap actuator motor (M39) from AC housing (1)		
6	Install in the reverse order		