

**TRANSMISSION 722.60# /61# /660 /662 /664 /665 /69# ## as of 1317917 as of 7.1.99,  
722.62# /63# /661 /663 /666 /669 ## as of 1324240 as of 12.1.99**

1 Needle bushing

The plain bearing in the input shaft was replaced by an anti-friction bearing (needle bushing).

As a result, the inside diameter of the needle bushing in the input shaft and the outside diameter of the journal at the output shaft have also changed.

When repairing a vehicle, therefore, both shafts must be replaced.

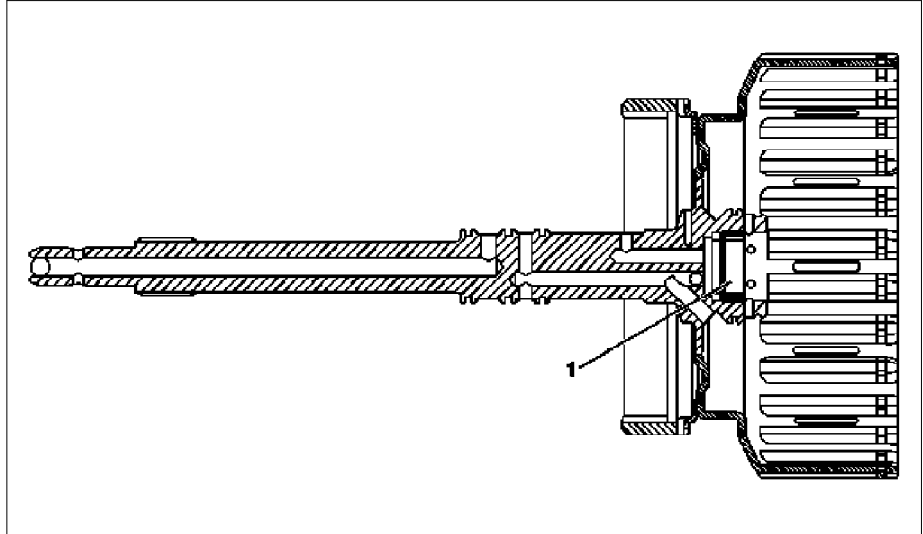

P27.51-2006-05