

ENGINE 112.910 in MODEL 202.026 /086
 ENGINE 112.920 in MODEL 202.029 /089
 ENGINE 112.911 in MODEL 210.061/261
 ENGINE 112.921 in MODEL 210.063 /263 /081 /281 /663
 ENGINE 112.941 in MODEL 210.065 /082 /265 /282
 ENGINE 112.940 in MODEL 208.365 /465
 ENGINE 112.942 in MODEL 163.154
 ENGINE 112.970 in MODEL 163.157
 ENGINE 113.940 in MODEL 210.070 /270

Shown on Engine 112

1/2 Right crankcase vent line
 2 Air cleaner
 2/1 Resonance housing
 2/2 Air intake tube
 2/3 Bolt
 B2/5 Hot film mass air flow sensor

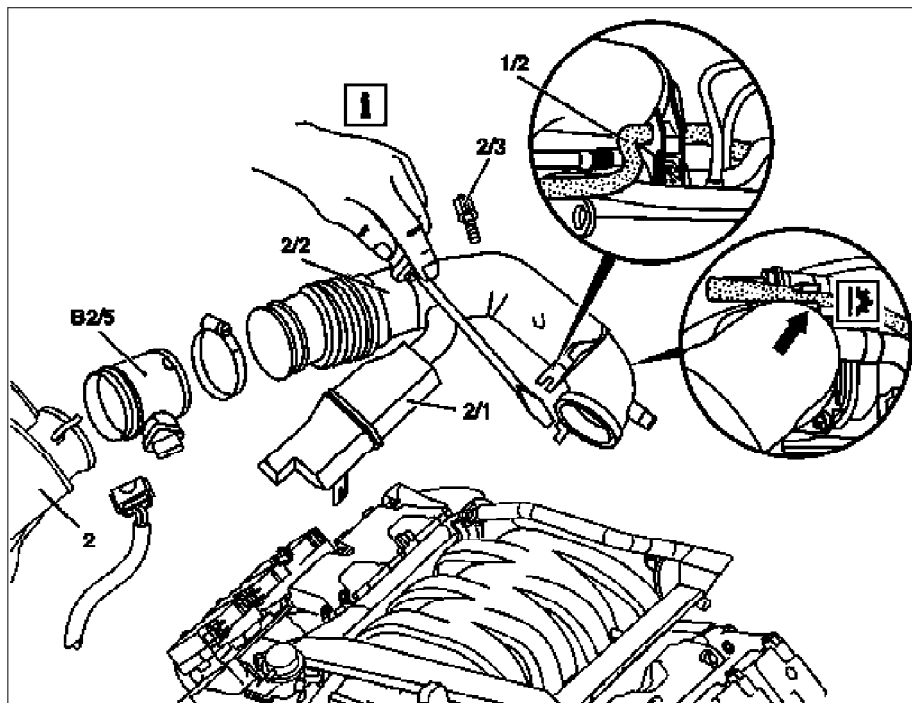

P07.61-0440-06

Fig. item, etc.	Work instructions		
	Cable actuator of electronic accelerator	Removal: Before the air intake tube (2/2) is removed, detach cable (arrow)	
	Lock of air intake tube to actuator electronic accelerator	Removal: Press plate to bottom by means of screwdriver	
1/2	Right crankcase vent line	Installation: Slip-on from below	
2	Air filter		
2/1	Resonance housing	Detach from above out of the rubber mounting	
2/2	Air intake pipe	Bolt (2/3)	
B2/5	Hot film MAF sensor	Unplug electrical connector. Slacken hose clamp	