

MODEL 163.154 /172 #A as of 145273,
163.136 /154 /172 #X as of 708319,
163.113 /128 /157 /175 with CODE (847) 3rd seat row

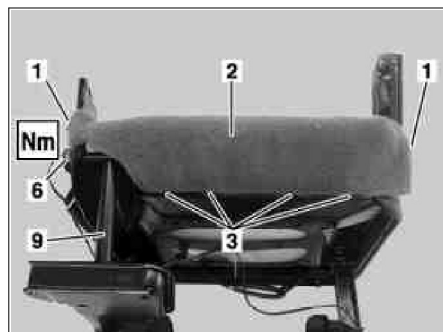

P91.12-2153-01

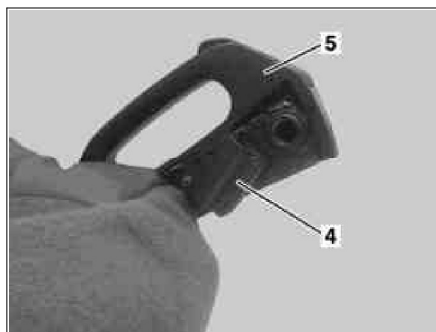

P91.12-2154-01



P91.12-2155-01

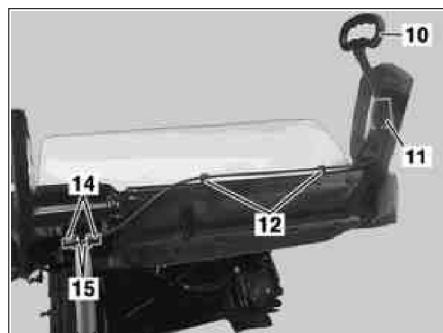

P91.12-2156-01

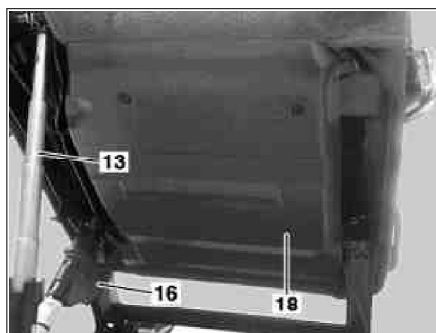

P91.12-2157-01



P91.12-2158-01

- 24 Heat-shrinkable tube
25 Heat-shrinkable tube



P91.12-2446-01

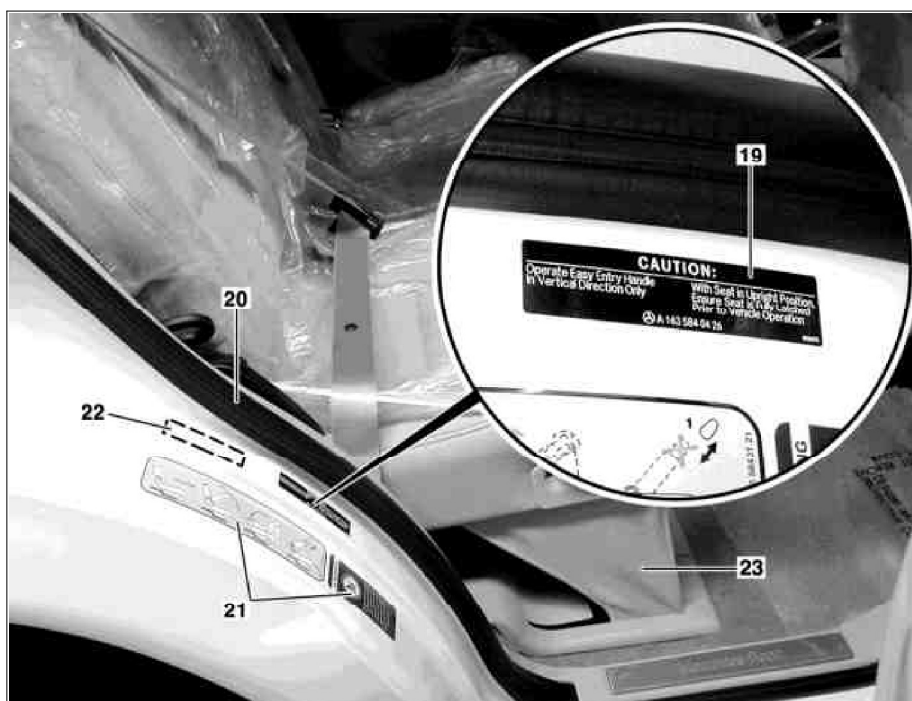

- 19 Sticker with instructions for use for easy entry in English
20 Rubber door seal for rear doors
21 Sticker
22 Sticker with instructions for use for easy entry in French
23 Curtain



P91.12-2445-06



Remove

1 f	Remove 40% rear seat Remove and install bench		AR91.12-P-1010GI
2 f	Remove folding backrest on 40% rear seat Remove/install tilting rear seat		AR91.12-P-1720GI
3	Pull off Velcro strips (1) on back of seat cover (2)		
4	Detach seat cover (2) from back of seat frame (3)		
5	Remove cover (4) on inside of release lever (5)		
6	Unscrew bolt (6) on support (9)		
7	Remove bolt or pin (7) at bottom of support (9) and remove support	i Up to VIN A152440 a bolt has been used for securing the support # Replace rear seat bearing.	AN91.12-P-0002-01A
	Install		
8	Install long gas-filled spring strut on the outside left side		
9	Attach release mechanism (11) with handle (10) to release lever	i Insert the pin at the rear cleanly. Use the longer bolts for fastening.	
10	Insert clip retainers (12) on release cable into holes at top of seat frame	i Risk of breakage!	
11	Install telescopic arm (13) instead of support (9)	i The release clip (15) is seated in the larger recess in the telescopic arm housing and faces towards the rear. The longer section of the upper and lower telescopic arm mountings point towards the left side. Nm Nm	*BA91.40-P-1006-01D *BA91.12-P-1011-03A
12	Push a 25 mm long piece of heat-shrinkable tube (24) over the end of the release cable		
13	Insert the ends of the release cables (14) in the release clip (15)		
14	Push the heat-shrinkable tube (24) on the inside over the release cable (14) and release clip (15)		
15	Push a second 25 mm long piece of heat-shrinkable tube (25) on the outside over the release cable (14) and release clip (15)		
16	Carefully heat up heat-shrinkable tube and shrink onto the release cable and release clip	i Do not damage seat cover due to exposure to heat.  Hot air gun	*WE58.40-Z-1007-03A
17	Install cover (16)		
18	Install rubber stop (17) on front of seat frame		
19	Attach seat cover (2) to rear of seat frame		
20	Fasten Velcro strips (1) on back of seat cover (2)		
21	Screw on cover (18) on underside of seat frame	i Copy the positions of the holes from the cover on the seat frame if there are no holes present.	
22 f	Install folding backrest on 40% rear seat Remove/install tilting rear seat		AR91.12-P-1720GI
23 f	Install 40% rear seat Remove and install bench		AR91.12-P-1010GI
24	Replace side curtain (23) on 40% bench seat	i Modified curtain is included in the parts kit.	
25	Affix sticker with instructions for use for easy entry in English (19) on C-pillar	i between rubber door seal for rear doors (20) and existing stickers (21).	
26.1	Affix sticker with instructions for use for easy entry in French (22) onto C-pillar	i Only additional parts code 460 on vehicles for Canada. Attach immediately behind the sticker in English.	
27	Perform function check		

 Seat belts/emergency tensioning retractors

Number	Designation	Model 163 as of 09/99
BA91.40-P-1006-01D	Bolt, belt buckle to rear seat	Nm 45

Nm Rear seats

Number	Designation	Model 163 as of 09/99
BA91.12-P-1011-03A	Bolt, telescopic arm to bearing	Nm 45

Workshop equipment/MB testers (see Workshop Equipment Manual)

WE58.40-Z-1007-03A	Hot air blower
--------------------	----------------

Parts ordering notes

Part no.	Designation	Quantity
	 The following parts are only required up to VIN A152440 for replacing the support on the 40% seat.	
KG92 (see EPC)	Bracket	1
KG92 (see EPC)	Bolt	1