

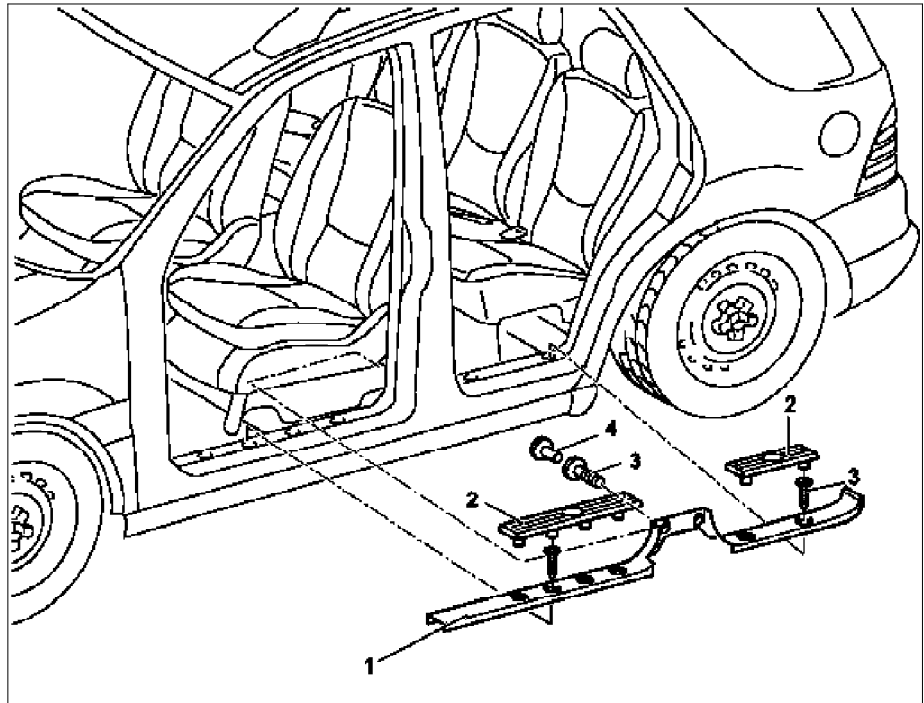







## MODELS 163.113 /128 /136 /154 /157 /172 /174 /175

- 1 Door sill molding
- 2 Cover
- 3 Bolt
- 4 Cover cap



P68.30-0534-06

 	Remove/install		
1	Remove covers (2) from door sill molding (1) upward	 <b>Up to 08/99:</b> Start at center of covers so that retaining lugs of covers are not damaged.	
		 <b>As of 09/99:</b> Start at the front of the front covering and the rear of the rear covering in order not to damage the retaining lugs.	
2	Unscrew screws (3) on door sill molding (1)		
3	Remove cap (4) on B-pillar		
4	Unscrew screws (3) from B-pillar		
5.1	Remove rear pin from door sill molding (1)	 Up to 08/99.	
6	Pull out the door sill molding (1) on the C-pillar paneling forwards	 <b>Danger of breaking!</b>  <b>Installation:</b> Use an assembly wedge to lift up the C-pillar paneling and door seal until the door sill molding can be inserted without any problems.	
		 Assembly wedge	*110589035900
7	Install in the reverse order		

