

MODELS 163.136 /154 /172 #A as of 145273,
 163.136 /154 /172 #X as of 708319,
 163.113 /128 /174 /175

The template shown is for the left side
 (turn over for the right side)

- 6 Template
 - 7 Hole, hinge assembly bolt, rear
 - 8 Hole, hinge assembly bolt, front
 - 9 Center punch position
 - 10 Center punch position
 - 11 Center punch position
- a 80 mm
 b 100 mm

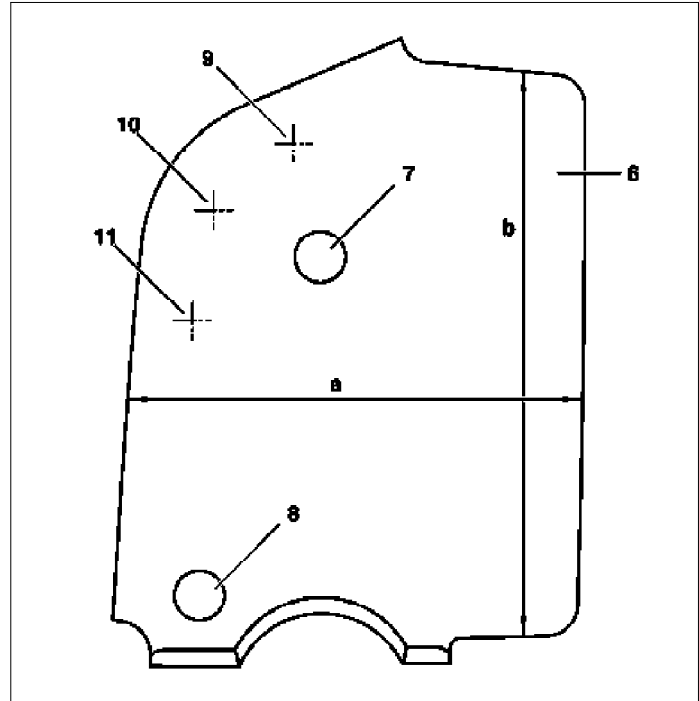

P63.20-3439-12

- 1 Hinge assembly bolt, front
- 2 Hinge assembly bolt, rear
- 3 Center punch mark
- 4 Center punch mark
- 5 Center punch mark

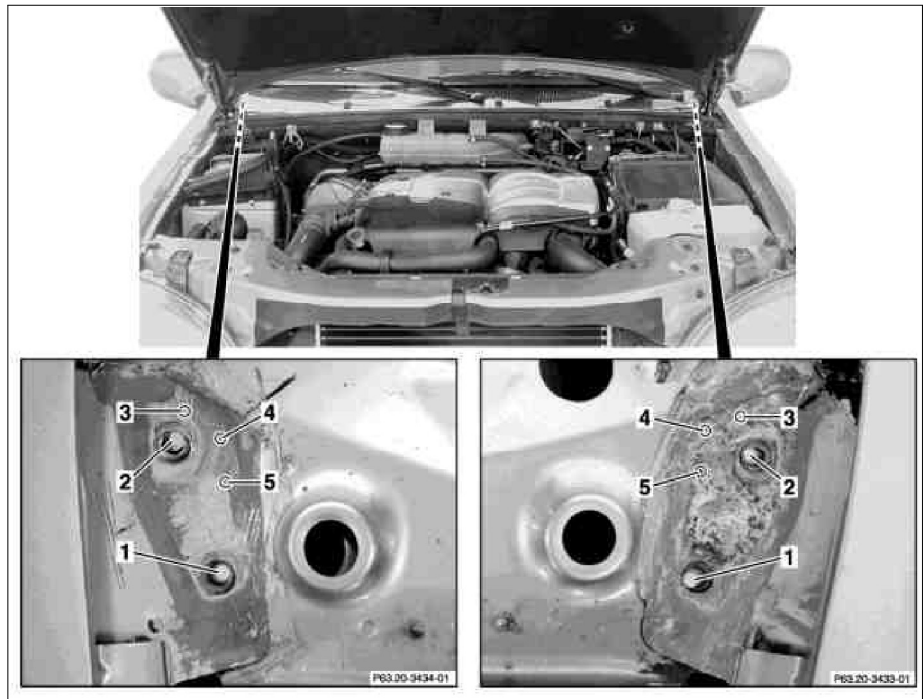

P63.20-3435-06

Operation no. of operation texts or standard texts and flat rates

Range	Op. no.	Operation text	Time	Acc. no.	Code
P	023540	REINFORCE LEFT ENGINE HOOD HINGE SUPPORT	037 WU/3.1 h	88 237 36	---
P	023541	REINFORCE RIGHT ENGINE HOOD HINGE SUPPORT	040 WU/3.3 hrs.	88 237 36	---
P	023542	REINFORCE (BOTH) ENGINE HOOD HINGE SUPPORTS	053 WU/4.4 hrs.	88 237 36	---

Remove/install		
1	Remove engine hood	AR88.40-P-3000GH
2	Remove wiper system	AR82.30-P-6400GH
3	Remove engine hood hinge on driver side	AR88.40-P-3060GH *BR00.45-Z-1004-01A

4	⚠ Danger! Risk of explosion from explosive gas. Risk of poisoning and caustic burns from swallowing battery electrolyte. Risk of injury through burns to skin and eyes from battery acid or when handling damaged lead-acid batteries Remove battery	No fire, sparks, naked flames or smoking. Wear protective gloves, acid-resistant clothing and safety glasses. Pour battery electrolyte only into suitable and appropriately marked containers.	AS54.10-Z-0001-01A AR54.10-P-0005GH
5	Press out template (6) and adapt the size to the correct dimensions (a, b)	Determine ACTUAL dimension (a) from the drawing. Divide the SPECIFIED dimension (a) by the determined ACTUAL dimension (a) and copy the template to the original size with the corresponding factor. i Check dimensions for both axes.	
6	Cut out template		
7	Cut out holes (7, 8) for engine hood hinge studs		
8	Position template in the engine hood hinge support using the stud holes	i The template is drawn for the left side. Turn over to obtain the right side.	
9	Center the engine hood hinge support on the template using the markings (9, 10, 11)		
10	Remove template		
11	Drill a hole at each center punch mark (3, 4, 5)	⚠ Only drill through the 2 upper panels. Do not drill through the reinforcement panel (3rd panel). Ⓢ	*201589005100
12	Cover windshield, paint surface and adjacent components adequately in order to avoid damage due to welding work General information on repairs to body	⚠ Cover apertures in the body in order to prevent flying sparks: the foam in the instrument panel burns easily.	AH60.00-N-0001-01A
C			
13	⚠ Danger! The high voltage used for arc welding presents a lethal hazard. Explosion hazard when welding in area of materials easily inflammable. Injury hazard from welding spatter and UV-light while welding. Risk of poisoning when inhaling welding vapors. Plug weld each hole	Use insulating mats. Wear protective clothing, safety glasses, and protective mask. Remove highly inflammable materials from the danger zone. Use air extractor.	AS00.00-Z-0007-01A *WE58.40-Z-1005-02A
14	Plug welds should be flat and ground smooth		
15	Remove covers and clean the repair area		
16	Prime untreated points in the area of the engine hood hinge support		
17	Prime the underside of the reinforcement panel of the engine hood hinge	i Access to underside of engine hood hinge support through the recess for the wiper motor.	
18	Spray the underside of the reinforcement panel of the engine hood hinge support with wax preservative	i Access to underside of engine hood hinge support through the recess for the wiper motor.	
19	Install in the reverse order		

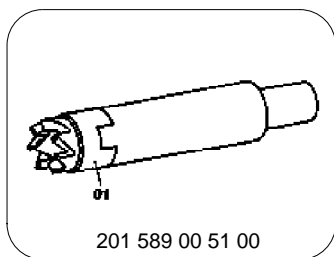

201 589 00 51 00

Weld spot miller

Workshop equipment/MB testers (see Workshop Equipment Manual)

WE58.40-Z-1005-02A	MIG inert gas welding equipment, aluminum weldable, sold by company Wieländer & Schill
--------------------	--

Repair products

Number	Designation	Order number
BR00.45-Z-1004-01A	MB body sealant for sealing seams (suitable for painting)	001 989 63 20

Parts ordering notes

Part no.	Designation	Quantity
000 986 06 50	Priming stick	1
000 986 33 70 10	Wax preservative	1