

A. General

The KE injection is a system with mechanically/hydraulically controlled basic functions and electronically controlled additional functions.

The designation KE means:

K=Continuous fuel injection

E=Electronically controlled mixture adaptation

The KE injection system is a further development of the mechanical/hydraulic KA injection system and has gradually replaced the latter on the 4-, 6- and 8-cylinder engines.

The quantity of air inducted by the engine is controlled by the throttle valve and measured by the air flow sensor. The latter is positioned at the intake air flow upstream of the throttle valve. The fuel distributor meters the quantity of fuel to the individual cylinders of the engine in line with the quantity of air measured.

The fuel is passed to the injection valves which inject the fuel continuously in a finely atomized spray into the intake port downstream of the injection valves.

Components of the KE injection system

The operating states, such as starting, warming-up, acceleration, full load, KAT operation with lambda control, deceleration mode etc. are detected by sensors and signalled to the KE control unit. The KE control unit processes this information and influences the composition of the mixture by means of the electrohydraulic actuator fitted to the fuel distributor.

The KE injection system has good emergency running properties in the event of a failure of the electronic mixture adaptation.

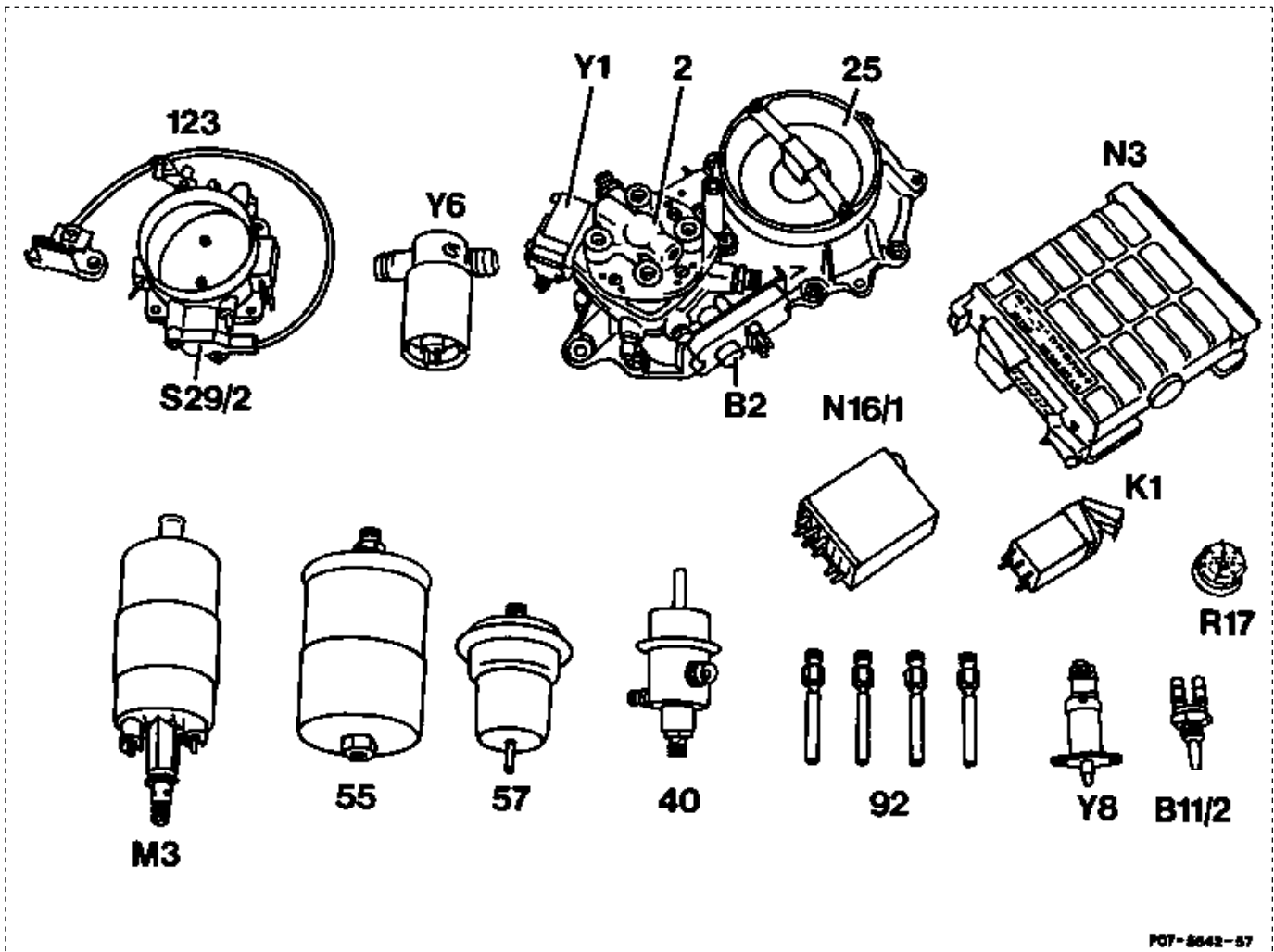

PGF-8642-57

B2	Air flow sensor position indicator	Y6	Idle speed adjuster
B11/2	Coolant temperature sensor	Y8	Start valve
S29/2	Throttle valve switch	2	Fuel distributor
R17	KE injection system resistance trimming plug	25	Air flow sensor
N16/1	Fuel pump relay	40	Diaphragm pressure regulator
N3	KE control unit	55	Fuel filter
K1	Overvoltage protection relay	57	Fuel accumulator
Y1	Electrohydraulic actuator	92	Injection valves
M3	Fuel pump	123	Throttle valve body

Interaction of the components

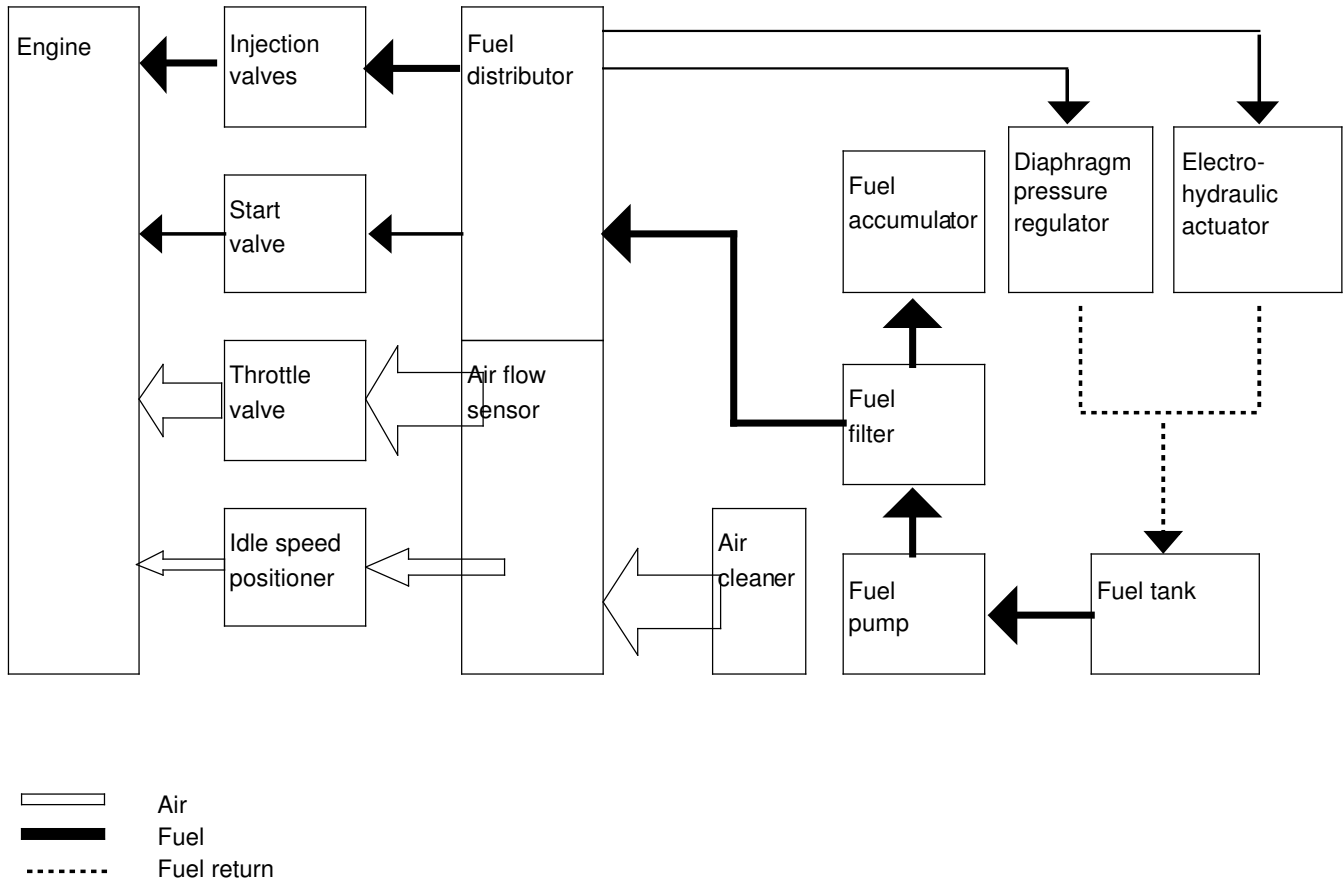

The KE injection system is divided into the following function groups:

- Fuel supply
- Mixture formation
- Functions in the KE control unit
- Further electrical components and functions
- Start device
- Idle speed device
- Emissions control (see Group 14 and 49)