

AR40.10-P-1040-01A	Mounting centering sleeve		
--------------------	---------------------------	--	--

Commercially available tools (see Workshop Equipment Manual)

Number	Designation	Make (e.g.)	Order number
WH58.30-Z-1003-18A	Centering sleeve DUO-FLEX 2 When ordering, state flange shaft diameter and model of balancing machine	Haweke D-30928 Burgwedel	16 100 8006
WH58.30-Z-1004-18A	Conversion kit	Hofmann D-64319 Pfungstadt	6416 451

- 1 Because of the segment centering of the rims, the wheel balancing machines approved by Mercedes-Benz must be used with a centering sleeve (arrow).
- 2 The centering sleeve ensures that the rim is mounted much more securely on the balancing machine and eliminates balancing errors.

Haweke centering sleeve

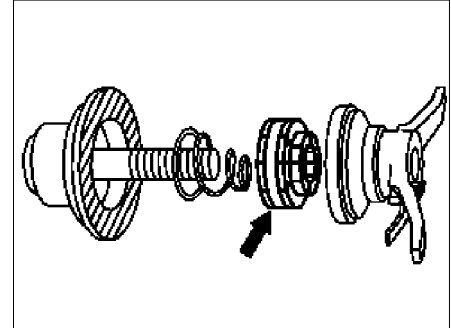

P40.10-0212-01

Hofmann centering sleeve

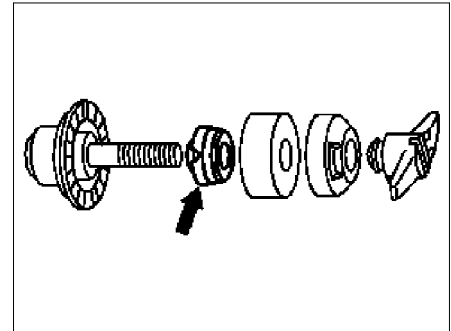

P40.10-0213-01